



RC25E5 / RC25B5

TEMPERATURE	PRIME	STANDBY
40°C	20 KW	22 KW
40°C	25 KVA	28 KVA

SAFETY PROTECTION:

- Water Temp.
- Oil Pressure
- Emergency Stop Button
- Battery Disconnect
- Lockable Voltage Selection
- Generator Output Protection.

OVERALL SPECIFICATION

- Frequency:50 Hz
- Voltage:400V / AC
- Engine Speed:1500RPM
- Fuel Tank Capacity:185L
- Oil Capacity:11L
- Gross Engine Power Output:32HP (24KW)
- Sound Level (Full Load):75 dB(A) / 7m
- Weight: (Open)..... 850kg
(Canopy).....1300 kg
- Dimension: (Open).....1800 x 720 x 1200 (mm)
(Canopy).....2420 x 1100 x 1650 (mm)

ENGINE

- Engine Model: 4B3.9-G2
- Number of Cylinders:4
- Bore x Stroke:102 x 120 (mm)
- Displacement:3.9 (L)
- Aspiration:Natural
- Combustion System:Direct Injection
- Compression Ratio:16.5 : 1
- Cooling System:Water - cooling
- Lubrication Capacity:11 (L)
- Coolant Capacity:8 (L)
- Consumption :6.7 (L/h)

ALTERNATOR

- Alternator Model:PI144E
- AVR:AS480
- Control System:Brushless, Self Excited
- Windings:100% Copper
- Winding Pitch:Two Thirds
- Winding Leads:12
- Insulation Class:Class H
- Protection:IP23
- Altitude:≤ 1000 (m)
- Bearing:Single
- Weight:135 kg

CUMMINS ENGINE

FEATURES

- Genuine CUMMINS diesel engine
- Low in fuel consumption
- Low exhaust emissions

EMISSION

High-tech injection and charging system with low internal losses contributes to excellent combustion and low fuel consumption.

DURABILITY AND LOW NOISE

Critical parts are designed with high tolerance ratio up to at least 30%, resulting in long lasting and reliable performance under almost all operation conditions. Reduced total number of parts has lead to lower maintenance and operation costs to almost 50%, comparing to some engines with traditional designs.

STARTING SYSTEM

24 VDC negative earthed starter, battery charging alternator.

FILTERING SYSTEM

Air cleaner with dry element and restriction indicator; spin-on full flow and by-pass lube oil filter and corrosion resistor coolant filter.



STAMFORD ALTERNATOR

APPLICATIONS

Alternators are designed to be suitable for typical generator applications, such as: backup, standard production, co-generation, rental, telecommunications, etc.



STANDARD OF COMPLIANCE

Alternators conform to the main international standards and regulations: IEC60034, NEMA MG1.22, ISO 8528, CSA, CSA/UL, etc. Alternators are designed, manufactured and marketed in an ISO 9001 environment.

TOP OF THE RANGE ELECTRICAL PERFORMANCE

- Class H insulation
- Standard 12-wire re-connectable winding, 2/3 pitch, type number 6
- High efficiency and motor starting capacity.
- Total harmonic content <2.5%

CONDITIONS AND DEFINITIONS

Prime Power Rating:

Prime power rating is applicable for unlimited number of operation hour per year in variable load condition. Variable load should not exceed 70% of Prime Power in average of total operation. A 10% overload is allowed for 1 hour in every 12 hour of consecutive operation.

Standby Power Rating:

Continuous running at variable load for emergency power. No overload is allowed.

Sound Level:

Sound level is measured at 7 m.

The canopies are made of high quality steel and powder coated. The paint is highly enduring against erosion and scratch, and strstrongly ongly rustproof.

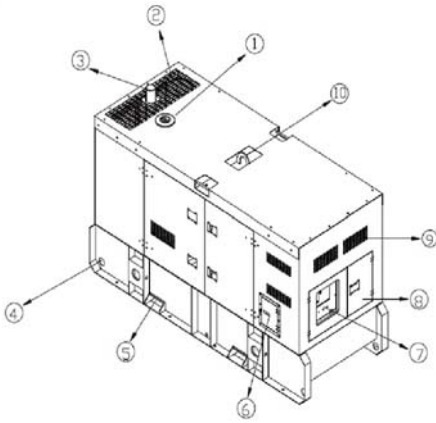

Standard Features

- | | |
|---------------------------|------------------|
| 1. Coolant Inlet | 6. Fuel Filler |
| 2. Silencer Mesh | 7. Control Panel |
| 3. Exhaust Gas Outlet | 8. MCB Door |
| 4. Holes for Transfer Car | 9. Air Inlet |
| 5. Fork Lift Channel | 10. Lifting Lug |



Fuel Filler



Wiring Diagram

Standard Features

- | | |
|---------------------------|----------------|
| 11. Voltage Change Switch | 16. Air Inlet |
| 12. Emergency Stop | 17. Base Frame |
| 13. Output Panel Cover | 18. Canopy |
| 14. Fuel Drain | 19. Door Lock |
| 15. Containment Drain | 20. Roping Lug |

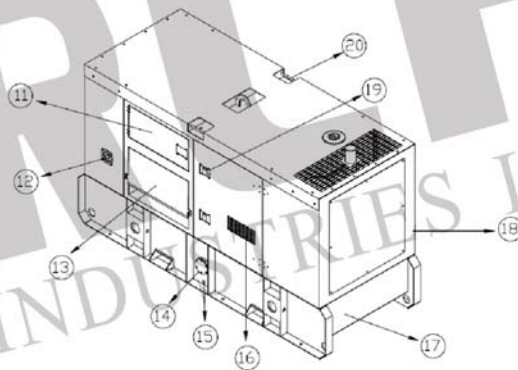

Adjustable Hinge



Heater Jacket

Power Coated



Radiator



Output Terminals



Cummins Engine



Control Panel & MCB



RLP offer range of Standard and Optional features to our generator to meet your power needs as following:

Notes:		● means standard feature	○ stands optional features		
ENGINE	4 stroke Water-cooled Diesel Engine	●	FUEL SYSTEM	Base Fuel Tank	●
	Industrial Silencer	●		Fuel Tank Breather	●
	Oil Sump Pump	○		External Fuel Fill Access	●
	Coolant Heater 220/240 V	○		2/3 Ways Fuel Valve (Internal / External Supply)	●
	Air Filter	●		Low Level Fuel Switch	●
ALERNATOR	Permanent Magnet Generator (PMG)	●	FUEL SYSTEM	Fuel Level Sender	○
	MX341 AVR	●		Base Fuel Tank	●
	Winding Temperature Sensor	○		Fuel Tank Breather	●
	IP23 Single Bearing, Class H insulation	●		External Fuel Fill Access	●
	Anti-condensation heater 220/240V	○		2/3 Ways Fuel Valve (Internal / External Supply)	●
COOLING SYSTEM	Radiator for 40 C Ambient Temp.	●	FUEL SYSTEM	Low Level Fuel Switch	●
	Low Coolant Level Protection	●		Fuel Level Sender	○
	Engine Driven Cooling Fan	●		Base Fuel Tank	●
	Charge Air Intercooler	●		Fuel Tank Breather	●
STARTING SYSTEM	Lockable Battery Isolator	●	FUEL SYSTEM	External Fuel Fill Access	●
	Battery Cables	●		2/3 Ways Fuel Valve (Internal / External Supply)	●
	2x12V Starting Battery	●		Low Level Fuel Switch	●
	Static Battery Charger (220/240V)	○		Fuel Level Sender	○
	Battery Charging Alternator	●		Fuel Level Sender	○
	Jump Start Receptacle	○		Parts Manual	●
CONTROL SYSTEM	Deepsea 7310 Controller	●	DOCUMENTS SYSTEM	Warranty Manual	●
	Compact Paralleling Controller	○		CE	●
	Communication Card	○		Other	○

Controlled by DEEPSEA 7310



The DSE7310 is an Auto Start Control Module. Monitoring an extensive number of engine parameters, the modules will display warnings, shutdown and engine status information on the back-lit LCD screen, illuminated LEDs, remote PC and via SMS text alerts (with external modem).

The module includes USB, RS232 port as well as dedicated DSENet[®] terminals for expansion device connectivity.

The module is simple to operate and feature a user-friendly menu layout for improved clarity. Enhanced features include a real time clock for enhanced event and performance monitoring, ethernet communications for low cost monitoring, mutual standby (DSE7310 only) to reduce engine wear and tear and preventative maintenance features to detect engine part faults prior to a major problem occurring.

FEATURES

- Backed up real time clock
- 132 x 64 pixel LCD display
- Configurable display languages
- Five-key menu navigation
- Fully configurable via PC software
- LED and LCD alarm indication
- Engine exercise mode
- Configurable start & fuel outputs
- kWh monitoring
- Automatic load transfer
- Eight configurable digital inputs
- Six configurable outputs
- Configurable timers and alarms
- Modbus RTU
- Magnetic pick-up
- Selected front panel programming
- Multiple date and time exercise scheduler
- SMS messaging (additional external modem required)
- Power save mode
- User selectable RS232 communications
- DSENet[®] compatible
- Ethernet communications via DSE860
- Multiple date and time maintenance scheduler
- Configurable display pages
- Programmable load shedding/acceptance
- Preventative maintenance
- kW overload protection
- Unbalanced load protection
- Flexible sender input
- Configurable SCADA output page
- True dual mutual standby with load balancing timer (DSE7310 only)
- Fan control for additional cooling
- 'Protections Disabled' facility
- Fuel usage monitoring and low fuel alarm
- Support for up to three remote display units
- Automatic sleep mode
- Easy access, configurable diagnostics page shows summary of output states
- Improved programmable event log (250) showing date and time
- Manual fuel pump control
- 3 alternative configurations
- Multiple date and time scheduler
- 3 Programmable Maintenance alarms with comms alert
- Customisable status screens
- Low fuel level alarm delay
- Charge alternator fail warning and shutdown alarms with user programmable delay
- Independent Earth fault trip
- Sleep mode
- Load switching (Load shedding and dummy load outputs)
- Manual speed trim (on CAN engines that support this feature)
- Additional display screens to help with modem diagnostics
- Security levels – PC software has password system to control access to PC software features
- Operator configurable virtual LEDs visible in SCADA

NEW FEATURES

- Additional programmable logic
- Improved modem diagnostics
- Remote control sources (10) can be accessed via SCADA
- Additional electrical trip options
- Additional start delay functions
- Oil pressure values from additional engines
- Front panel editing of scheduler
- Displays kW as % of rated kW setting

OPERATION

The module is operated via the START, STOP, AUTO and MANUAL soft touch membrane buttons on the front panel. And the module includes loadswitch buttons. The main menu system is accessed using the five navigation buttons to the left of the LCD display.

CONFIGURATION

The module can be configured using the front panel buttons or by using the DSE Configuration Suite PC software and a USB lead.

COMMUNICATIONS

The DSE7310 have a number of different communication capabilities.

INPUTS & OUTPUTS

Analogue inputs are provided for oil pressure, coolant temperature and fuel level. These connect to conventional engine mounted resistive sensor units to provide accurate monitoring and protection facilities. They can also be configured to interface with digital switch type inputs for low oil pressure and high coolant temperature shutdowns. Eight user configurable digital inputs are also included, plus one flexible sender.

Outputs are provided for fuel solenoid, start solenoid and six additional configurable outputs. On these configurable outputs a range of different functions, conditions or alarms can be selected.

INSTRUMENTATION

The module provides advanced metering facilities, displaying the information on the LCD display. The information can be accessed using the five-key menu navigation to the left of the display.